

# 1994 STEEL BRIDGE BUILDING COMPETITION

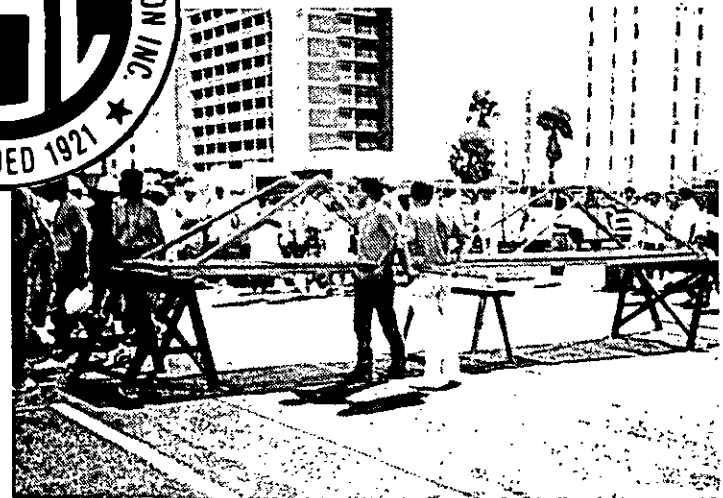

FOR STUDENT CHAPTERS OF  
THE AMERICAN SOCIETY OF CIVIL ENGINEERS

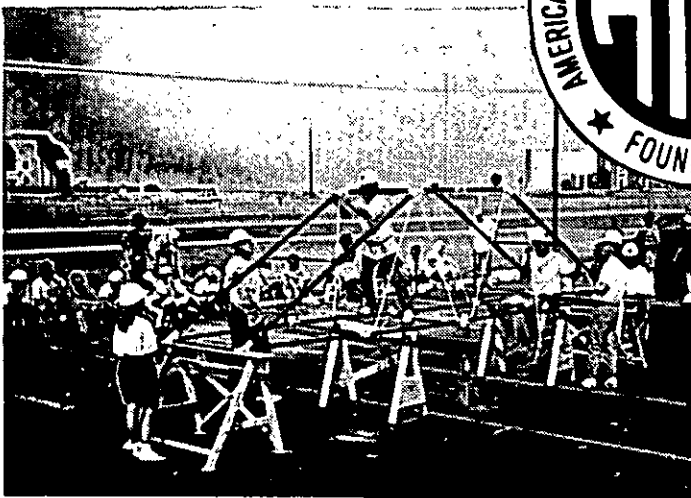
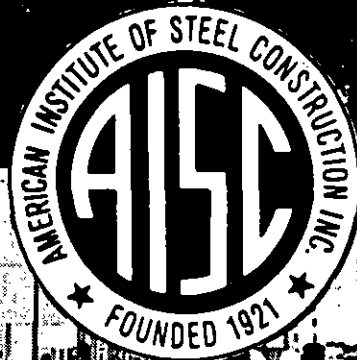
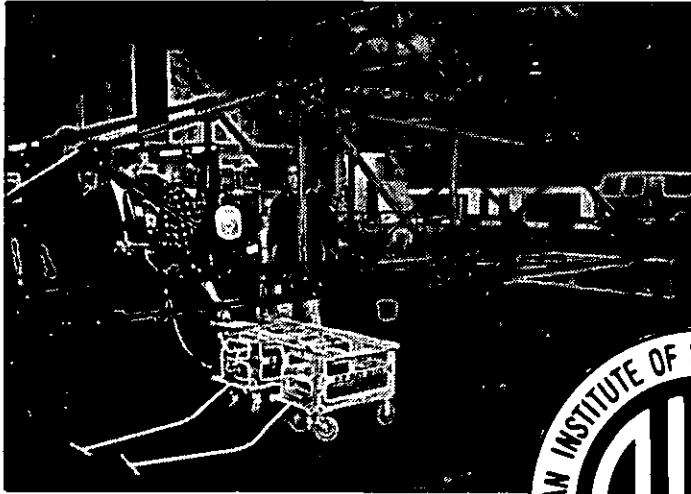

IN COOPERATION WITH **ASCE** AMERICAN SOCIETY OF CIVIL ENGINEERS

## **STATEMENT**

The Steel Bridge-Building Competition is sponsored by the American Institute of Steel Construction. It challenges civil engineering students to a competition that includes design and hands-on experience with structural steel.

Since the educational intent of the competition is to give engineering students exposure to designing, fabricating and erecting a steel bridge, AISC is recommending that the judging panel at each competition accepts only bridges substantially designed and built during the academic year in which the competition is held.

AISC places great emphasis on safety. The competing teams are asked to observe safety practices as covered in the competition rules.

**AISC 1994 STEEL BRIDGE-BUILDING  
COMPETITION RULES**

0115

## TABLE OF CONTENTS

Executive Summary	1
Problem Statement	2
Site Plan	4
Bridge Area Cross - Section	5
Qualification	6
Award Competition	6
Components	8
Construction	8
Safety Regulations	10
Dimensions and Support	11
Load Tests	12
Equipment Provided by Host Chapter	13
Modifying the Rules	14
Bridge-Building Tips	15
Notes for Host Chapter	16
Judging Form (Suggested)	20

0116

## EXECUTIVE SUMMARY

Civil Engineering students are challenged in a competition that includes design, hands-on experience with structural steel and the use of both actual and simulated construction practices in building a structure. Through the competition, you will utilize materials and design knowledge, construction planning, shop experience, training and teamwork.

In the opening Problem Statement, you are given an orientation into some of the real-life design and construction problems commonly encountered in actual practice. The Statement also establishes some background into the selection of the load tests and design/construction restrictions of the competition. The Problem Statement and related rules are basic to construction practices and are minimal when compared to the volumes of real-life regulations.

Member size and weight limitations are given for several reasons. First, it makes the competition representative of a real situation. Second, it causes you to look at several construction alternatives, rather than using a single member to span the entire 20-foot length. Third, it facilitates the handling and transportation of your structure to the competition site. Fourth, it minimizes the risk to you in handling and assembling the pieces.

Regulations and penalties have been established to maintain the integrity of the construction simulation. These rules are related to actual construction problems, just as members are scaled to model those size limitations found in an actual structure.

Several categories of competition are offered, so you should look at several design alternatives to win any or all of the categories. A latticework structure may be the lightest, but takes a long time to build. A cable-supported structure may be fast and light, but not meet deflection or stability considerations. Beam-type structures may be fast, but heavy and expensive. Several categories of competition allow you to target your objectives and design/build accordingly.

The competition promises design challenges, steel fabrication experience, the use of construction planning and practice, teamwork, plus the fun of competing against fellow students.

## **PROBLEM STATEMENT**

A century-old bridge across a river valley in a mountainous rural region is in need of replacement. The bridge serves not only area residents, but also important heavy truck traffic for area mining. No other river crossing of adequate capacity is available for miles in either direction, therefore, a quick replacement is necessary.

The State Department of Transportation has sought design/build proposals to construct a replacement bridge. Any type of steel structure will be permitted, but it must meet the following minimum design loads and construction restrictions:

1. The bridge must accommodate two lanes of traffic,
2. the bridge must be able to resist various patterns of gravity load,
3. the bridge must be able to resist a lateral force of 100,000 pounds from river flooding and/or wind forces,
4. no interior piers are permitted, easing environmental clearances,
5. no lateral thrusts or uplift can be applied to the existing abutments, nor can they be reinforced to accommodate such forces,
6. no backstays or anchorages are available beyond the abutment,
7. construction and live load deflection limits must be met,
8. and the bridge must accommodate state-supplied modular bridge deck units salvaged from another bridge, without modification to any unit.

The existing bridge spans in the north-south direction a distance of 200 feet, resting on simple stone abutments. The valley below is relatively flat, roughly 30 feet below the top of the abutments. The north river bank is 50 feet wide, the river itself is 70 feet wide, and the south bank is 80 feet wide.

The river is fast, not navigable and environmentally sensitive. Flash flooding and environmental concerns prohibit the use of barges, causeways or scaffolding across the river. Temporary shoring can be safely placed on the solid banks of the river.

Storage and staging yards 150 feet square will be cleared for the contractor's use at both ends of the bridge. The yard at the north end of the bridge will be located just 100 feet from the abutment. The yard at the south end will be 300 feet from the abutment. The service road from both yards to the bridge will be widened to 50 feet, and will extend around one end of the abutment wingwalls down to the river banks.

Soil conditions, rough terrain and tight site conditions limit the lifting capacity of cranes. Materials may be delivered by crane to the river valley by using the access roads constructed around the wingwall, or by transferring the materials over the abutments or wingwalls from one crane to the next.

Narrow, winding roads lead to the yards from both directions. Because of this, the length of an individual member is limited to 55 feet, with a maximum width and depth of 6'-3". This enables the trucks to make the required turns. Smaller bridges on both sides of the main bridge being replaced limit the weight of an individual piece to 20 tons (40,000 pounds).

The state will provide prefabricated, 10" deep modular bridge deck units that were salvaged from another bridge. They are the required roadway width, 35 feet in the transverse direction. They are capable of spanning a 35-foot clear distance between supports, and are also capable of cantilevering 5 feet beyond a support.

To allow for a new bridge design, new approaches will be constructed that can go as high as 7'-1" above the top of the existing abutment. Allowing for the 10" depth of the state-supplied modular deck unit, the structure depth at abutments can be as deep as 6'-3", the same as the maximum member depth.

Your company's design/build proposal has been deemed responsive by the State Department of Transportation. To make a selection, the state has asked your firm and the other competing firms to construct a 1:10 model bridge, demonstrate the erection method to be used, then subject it to load testing. The state is concerned about many things in its evaluation -- strength, speed of construction, cost, stiffness, weight and aesthetics. Using a ranking system, it will use the competition to select a contractor winner. If your bridge is judged the best, your firm will receive a negotiated contract to build this bridge, and possibly several others. You and your firm could become leaders in the national bridge replacement market.

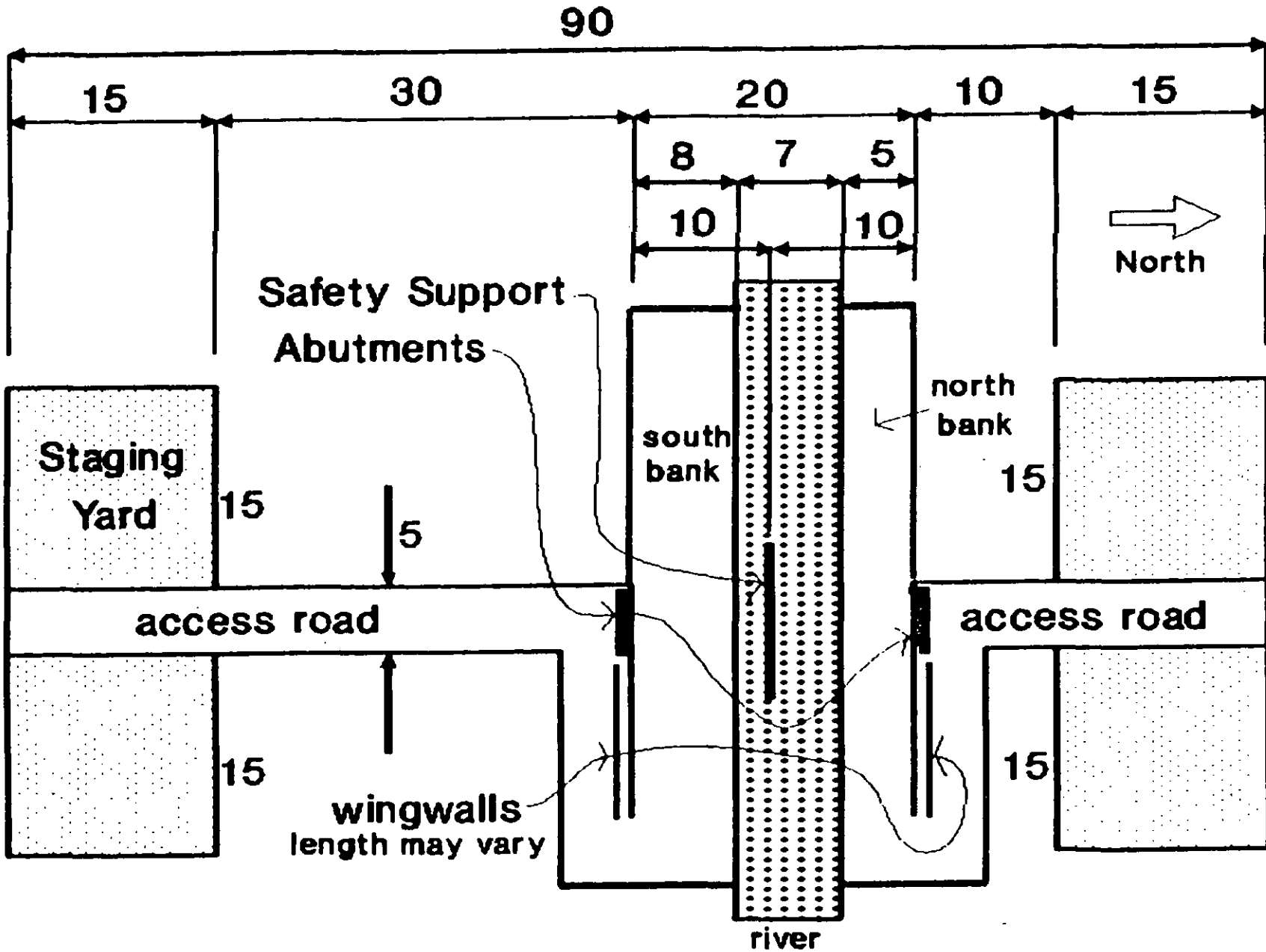

SITE PLAN



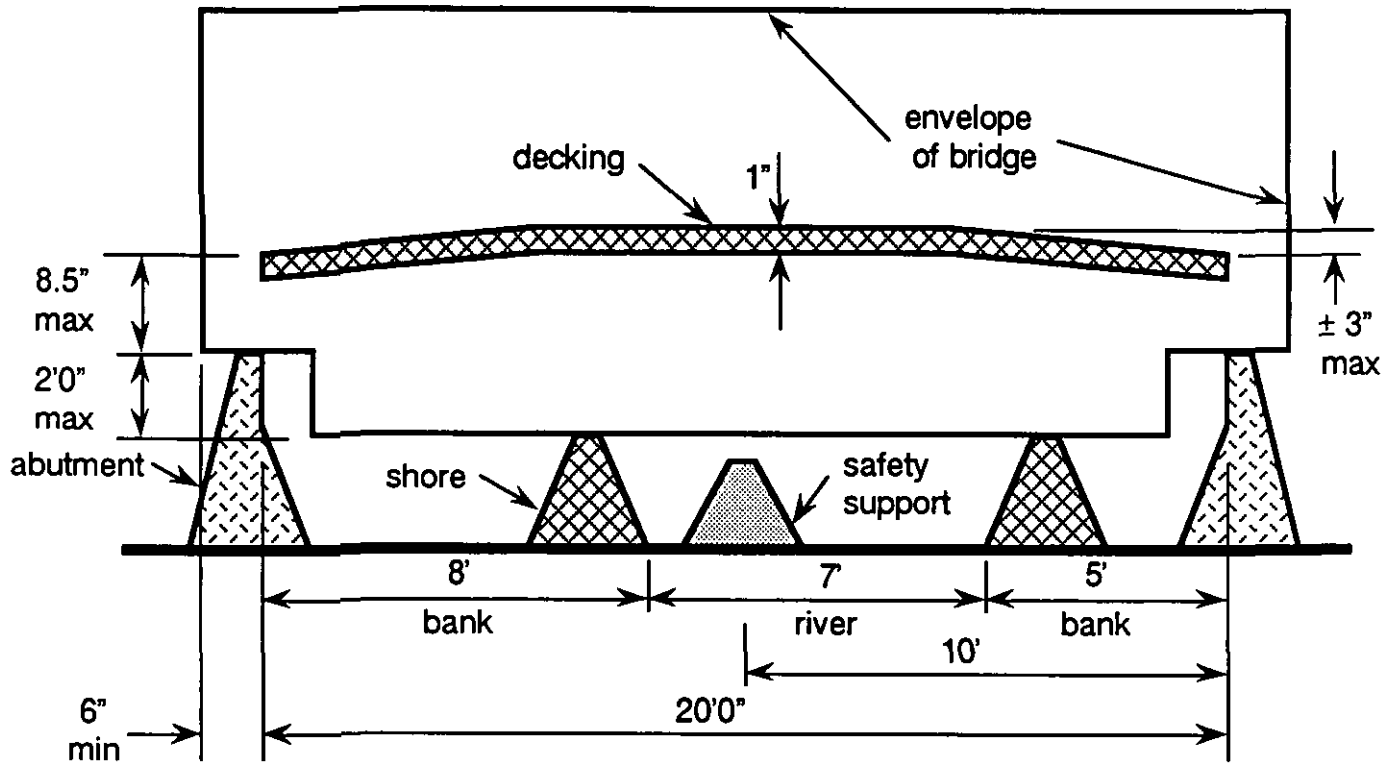

Side Elevation

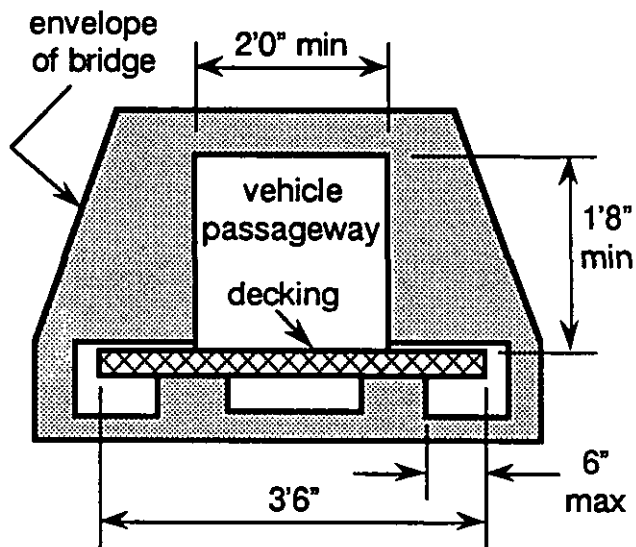

Clearance and Deck Support

## QUALIFICATION

In order to compete for awards, a bridge must qualify by satisfying the following minimum standards for durability, constructability, usability, strength and serviceability.

### Durability

The bridge must be constructed entirely of steel.

### Constructability

The bridge may be constructed only of components conforming to the restrictions on size and weight as specified in "Components". The bridge must be constructable without violating requirements listed in "Safety Regulations".

### Usability

The bridge must conform to the specifications described in "Dimensions and Support".

### Strength and Serviceability

The bridge must pass load tests 1 and 2 described in "Load Tests".

## AWARD COMPETITION

Only qualified bridges are eligible to compete for awards. Categories of competition are stiffness, lightness, construction speed, aesthetics, efficiency and economy. In addition, overall performance is rated.

### Stiffness

The bridge with the lowest incremental vertical deflection will win in the stiffness category. Incremental vertical deflection is determined from load test 3. A bridge that fails load test 3 will be eliminated from the stiffness and efficiency categories of competition.

### Lightness

The bridge with the least total weight will win in the lightness category. Decking and temporary shores are not included in total weight.

### Construction Speed

The bridge with the lowest construction time will win in this category. Construction time is the product of the size of the construction team and the duration of construction. The construction team includes everyone who handles the bridge or any of its components during timed construction. A bridge that accumulates \$150,000 or more in penalties will be eliminated from competition in the construction speed and economy categories (see "Accidents").

### Aesthetics

Is judged by a non-partisan jury following the competition of the bridge, but prior to load testing. Please see *Judging Form (suggested)* for items to consider.

### Efficiency

The bridge with the smallest sum of normalized weight and deflection ratios (SNWD) will win in the efficiency category. The sum of normalized weight and deflection ratios is computed as

$$SNWD = \frac{\text{Incremental vertical deflection (in)}}{0.10 \text{ (in)}} + \frac{\text{Total weight (lb)}}{100 \text{ (lb)}}$$

### Economy

The bridge with the smallest cost (C) will win in the economy category. Cost is computed as

$$C = \text{Total weight (lb)} \times 1000 \text{ (\$/lb)} + \\ \text{Construction time (pers-min)} \times 3000 \text{ (\$/pers-min)} + \\ [\$80,000 \text{ if temporary shores are used}] + [\text{Penalty costs}]$$

Penalty costs are listed in "Accidents."

### Overall Performance

The overall performance rating of a bridge is determined by adding the rank of the bridge in the efficiency category to its rank in the economy category. The bridge with the lowest sum will win the overall competition. A bridge that was eliminated from the efficiency and/or economy categories is not eligible for the

overall performance competition. In the case of a tie, judges may use aesthetics as the tie breaker.

## COMPONENTS

A bridge may be constructed only of components made entirely of steel, and conforming to the following descriptions of members, cables with fittings, assemblies, and fasteners.

A member may not weigh more than 40 pounds, nor exceed overall dimensions of 5'6" x 7.5" x 7.5" (that is, it must fit inside a cylinder with a diameter of 7.5"). A member may consist of parts connected together before timed construction begins, but it must be rigid (that is, hinged, articulated or telescoping members are not permitted).

A cable with fittings may not weigh more than 40 pounds and must be capable of being coiled to a diameter not exceeding two feet. Fittings are clamps, clevises, turnbuckles and similar parts used for connecting cables, and not exceeding 7.5" in any dimension. A cable with fittings may consist of parts connected together before timed construction begins; there is no limit on the number of ends.

An assembly is no more than 3 members and/or cables that are connected together in the staging yards during timed construction.

Fasteners are bolts and nuts, pins, shims and similar parts used for connection members, cables and assemblies, and not exceeding 7.5" in any dimension.

## CONSTRUCTION

### Construction Site

See the figure titled "Site Plan" for layout of river, banks, and other features that affect construction.

### Temporary Shores

Shores are temporary support on the river banks, and are provided by the builders. There are no restrictions on the materials and design for shores, other than that they be sufficiently strong and stable to support the bridge and builders.

There is a cost assigned to temporary shores; their advantage is that builders may be supported by the bridge only if shores are in place. If shores are used, they must be used on both banks.

### Start

Before construction begins, all members, cables with fittings, fasteners, tools and builders are in the staging yards. Temporary shores, if used, have been constructed and are in place on both river banks. The safety support is in place at the middle of the span and adjusted so that it will be close to the bottom of the bridge, unless the style of the bridge makes that impossible. Timing and construction begin when the builders signify that they are ready, and the judge declares the start.

### Time

Time is kept from the start to finish of construction. The clock will be stopped:

1. if a builder or judge sees a condition that could cause personal injury;
2. when a safety regulation has been violated, and
3. if the safety support must be moved or adjusted.

Construction ceases while the clock is stopped. The clock is restarted after the situation has been corrected.

### Finish

Construction ends when the bridge is complete and all tools, builders and shores are in the staging yards, and the builders signify that they are finished. Decking will be installed after the bridge is complete; installation is not included in timed construction.

### Tools

Builders provide their own tools. Only hand tools are permitted. Field welding, and power tools (electric and pneumatic) are prohibited. Ropes are permitted, but gin poles, jacks, winches, come-alongs, counterweights and other hoisting devices are prohibited. Stools, ladders, and similar objects for elevating builders are prohibited.

## **SAFETY REGULATIONS**

If one of the following safety regulations is violated, the judge will stop the clock and explain the violation. Before restarting the clock, builders, tools and bridge components will be returned to the positions they occupied before the violation. Construction that necessitates violation of safety regulations is not permitted.

1. If temporary shores are not used, a builder may not stand on the bridge or occupy it in any other way such that the bridge supports the builder's body weight. However, a builder may lean on the bridge if both feet remain on the river bank.
2. A builder may lift or carry only one member or cable with fittings at a time.
3. An assembly may not be lifted nor carried by one builder alone.
4. Two or more builders may lift or carry only one assembly at a time.
5. Nothing may be thrown.
6. A builder may not stand in the river.
7. A builder must stay within the limits of the access roads and river banks.
8. A builder may not cross the wingwalls.
9. The safety support as well as shores on both banks must be in place and properly adjusted before a builder climbs onto the bridge.
10. A builder may not cross the abutments except to climb onto the bridge with shores and safety support in place.
11. No member, cable or assembly may be carried while climbing onto the bridge.
12. A builder may not cross the river by jumping, by temporary scaffolding, or any other way except on a substantially completed bridge with shores and safety support in place.

13. A member, cable or assembly may not be laid down except in the staging yards, on the abutments, on the temporary shores and on the bridge. A member, cable or assembly may not be leaned against an abutment, shore, safety support, or the bridge.

14. A constructed portion of the bridge may be slid horizontally, provided that it is supported by any combination of two or more shores and abutments.

15. One side or end of a constructed portion of the bridge may be moved a few inches in any direction in order to align a connection.

### Accidents

In general, the clock is not stopped when an "accident" occurs. Builders involved in accidents may continue to build, and components involved in accidents may be recovered and used. Types of accidents and the corresponding cost penalties are:

1. A builder touches the river or the safety support. \$50,000 for each occurrence.
2. A member, cable, assembly, shore, or the bridge touches the river or the safety support. \$20,000 for each occurrence.
3. A tool or fastener is dropped into the river. \$1,000 for each occurrence.

### DIMENSIONS AND SUPPORT

The figures titled "Side Elevation" and "Clearance and Deck Support" illustrate some of the following specifications.

1. The bridge must span the abutments, which are fixed in place so that the distance between faces is 20'.
2. The bridge must provide at least 6" of bearing length behind the face of each abutment.
3. A 2'0" wide by 1'8" high rectangular vehicle passageway must be provided along the full length of the bridge.
4. No part of the bridge may extend more than 2'0" below the top of the abutments at any point on the span.

5. The surface of the deck must be no more than 8.5" above the top of the abutments, measured at the abutments.

6. The absolute value of camber must be less than 3".

7. The bridge must provide support of the decking such that the edges of the decking that run in the longitudinal direction of the bridge are cantilevered no more than 6".

8. The deck must be sufficiently even and smooth to allow a wheeled vehicle to pass from one end of the bridge to the other. Sections of decking must be butted together without gap or overlap. Small elevation differences, such as those caused by decking resting on bolt heads, are acceptable.

9. The decking must not be attached or anchored to the bridge.

10. The bridge may not be attached or anchored to the abutments, and it may bear only on the top surface of the abutments.

11. The bridge may not be anchored to the ground.

### **LOAD TESTS**

**CAUTION:** A bridge could collapse suddenly during load tests. Therefore, minimize the number of people near the bridge while it is being tested, and use a safety support positioned about 6" below the center of the bridge.

Load tests are conducted without shores. Load test 1 is conducted without decking; load tests 2 and 3 are conducted with decking installed.

The judge selects a side of the bridge and designates three target points on that side, as close to the level of the decking as possible, but not on the decking itself. The target points are located at mid- and quarter-spans (that is 10, 5 and 15 feet from the faces of the abutments.) All lateral deflection measurements are made to the mid-span target point. Vertical deflection measurements are made to all three target points; vertical deflection is the maximum absolute value of the three measurements.

Total lateral deflection is the absolute value of the horizontal distance of the mid-span target point from its position at the beginning of load test 2. Incremental vertical deflection is the maximum absolute value of the vertical distances of the three target points from their positions at the beginning of load test 3.



Load tests are conducted in numerical order.

### Load Test 1 - Qualifying , Lateral

As close as practical to the mid-span target point, apply a 100-pound force in the lateral direction. To pass load test 1, the lateral deflection of the bridge must not exceed 1.0". If the bridge does not pass load test 1, do not conduct any other load test. Remove the lateral load; it is not part of the remaining load tests.

### Load Test 2 - Qualifying, Vertical

Uniformly distribute load over an area symmetric about the middle of the deck and not exceeding 3 feet in the span direction. Terminate load test 2 when lateral deflection reaches 1.0" or vertical deflection reaches 2.0" or 500 pounds of load has been placed. A bridge passes load test 2 if 500 pounds of load was placed without a deflection limit being exceeded. If the bridge does not pass load test 2, do not conduct any other load test.

### Load Test 3 - Competition, Vertical

With the load from test 2 remaining in place, uniformly distribute additional load over an area symmetric about the middle of the deck and not exceeding 6 feet in the span direction. Terminate load test 3 when total lateral deflection reaches 2.0" or incremental vertical deflection reaches 2.0" or 2,000 pounds of additional load has been placed. A bridge passes load test 3 if 2,000 pounds of additional load was placed without a deflection limit being exceeded. If the bridge passes load test 3, record the incremental vertical deflection.

## EQUIPMENT PROVIDED BY HOST CHAPTER

### Decking

The decking is steel bar grating identified as W-19-4 (1 x 1/8). The dimensions of a piece of grating are 3'6" x 2'11-3/4" x 1". Grating has bending strength only in the direction of the main bars, which are 3'6" long. The grating will be installed with the main bars perpendicular to the length of the bridge, creating a roadway that is 3'6" wide. Therefore, support for the grating must be provided along the edges that are parallel to the length of the bridge. No support is needed for the edges of the grating that are perpendicular to the length of the bridge.

For the load tests, do not exceed 400 psf uniform load nor 500 pounds concentrated load. Do not load on a cantilevered portion of the grating.

### Abutments

The top surface of each abutment should be at least 5' long, 3" to 12" wide, level, smooth, and approximately 3' above the ground.

### Safety Support

The safety support is intended to limit the consequences of a bridge collapsing during construction or load tests, but should not come in contact with the bridge unless there is a collapse or excessive deflection. The safety support is placed at the middle of the span and adjusted so that the top of the support is close to the bottom of the bridge.

The safety support should be placed and adjusted to the proper height before the start of timed construction, if possible. If the style of the bridge requires that the safety support be placed or adjusted when the bridge is partially constructed, the clock will be stopped while the safety support is positioned. Builders are prohibited from being on the bridge unless the safety support is in place, as well as temporary shores on both banks.

## MODIFYING THE RULES

Modification of the rules is discouraged, so that bridges from all regions may compete nationally without disqualification and/or disadvantage. If the rules absolutely must be modified to accommodate local restrictions, the host chapter should notify competing chapters as early as possible. Changes in the rules must not compromise safety.

## BRIDGE-BUILDING TIPS

There are many bridge designs which could be suitable for the competition. Among these are beam-and-girder bridges, trusses of endless varieties, king-post and queen-posts, box girders, arches and cable-supported bridges.

Some bridge-building tips have been learned in previous competitions:

1. Try to keep the number of pieces to be field-assembled to a minimum. Match-mark those pieces whenever possible to insure proper installation.
2. Keep the number of field bolts to a minimum. It may not be necessary to have a minimum two-bolt connection at every joint, especially for secondary members. Consider color-coding bolt heads if two different bolt diameters are used. It may not be necessary to fully tighten every bolt. Some may need to be only finger-tight.
3. Make your bolt holes sufficiently larger than the bolt diameter to ease installation. Putting 5/16 inch diameter bolts through holes drilled 21/64th in two or more layers of steel is not an easy task.
4. Try to keep your bridge weight below 400 pounds. Bridges in the range of 150 to 300 pounds are common.
5. Practice your bridge erection under simulated erection conditions to reduce your construction time and uncover fabrication and construction errors. Make sure you practice all safety guidelines. Competitive bridges usually have construction times less than 50 person-minutes.
6. Do not stand, sit or lie on your bridge unless a safety support and both shores are in place. Do not load the bridge unless a safety support is in place.
7. Bridge painting is a nice touch for aesthetics. School colors, names, logos and similar items add to the spirit of competition.
8. To speed things along on competition day, have a preset plan for unloading, staging and erecting your bridge. Know in advance the required elevations of shoring and Safety Support, relative to the abutments, so that they can be quickly placed and adjusted.

9. Allow some tolerance for the grating or other bridge deck to be slightly larger than planned. Make sure you have enough clearance between structural members, bolt heads and shanks to place the grating on the bridge. Review the required orientation of the grating to make sure you have supported it near the ends of the main bearing bars, along the sides of the bridge.

10. If using cable for primary structural elements, remember that cable can stretch considerably under load. Loosely wound cable strands stretch the most. Rods or small, flat stock bars may be a suitable alternative.

11. Tubes that use "sleeve type" compression joints go together quickly and may not need bolting together. Finding the right size tubing material may be more difficult than finding other structural shapes.

12. Start design early in the year and find a nearby supplier for your materials. This will minimize costs for everyone and eliminate the last-minute rush.

Several factors should be considered when you determine the type of bridge you will build. What facilities are available to you to build your bridge? Are welders, torches, drills and other tools available in your shop or laboratory? How thick can the pieces be for the equipment you have? Do you have a nearby scrap yard, steel fabricator, steel erector, machine shop or contractor for materials and to help with difficult pieces?

Designing, fabricating and building your bridge can be a fun learning experience. Start early, plan, design, evaluate, build and practice. Enjoy the challenge and the competition.

### NOTES FOR HOST CHAPTER

1. Judges can come from a variety of sources, including your local ASCE Chapter. They can be local designers, engineers, contractors or unbiased faculty and students. Select one person to be the Chief Official to be the final voice for rules interpretation.

2. The safety support is intended to support the bridge and its load if the bridge collapses during construction or load testing. The safety support should have a capacity of at least 6,000 pounds, should have a broad base to assure stability, and should be sufficiently wide at the top to accommodate a sideways failure. The height of the safety support must be adjustable.

Safety supports can be constructed from steel, timber, concrete blocks, and/or automotive jack stands.

3. Abutments can be of any convenient material such as steel sawhorses or beams, timber blocking, masonry blocks or some combination of these materials. If the abutments are not level, twisting of the bridge along its length could make fit-up and assembly difficult and could affect its strength. Use of a carpenter's level and string or a surveying level is recommended. If your Regional Conference has not already secured a set of abutments for use in bridge-building competitions, local steel fabricators are generally willing to loan steel sawhorses from their shops.

Each abutment should be capable of supporting 2,000-pound point loads, and at least 4,000 pounds total. Make sure the abutments are stable and will not fall if inadvertently laterally loaded during construction or load testing. The abutments should rest on solid pavement or ground to minimize the possibility of sinking during loading.

4. The method of applying loads during load testing is very important. Your available resources will determine this for you. Steel scrap beams, steel scrap pieces or hole punching in gunny sacks, concrete blocks, sand bags, tractor weights, water in drums, hydraulic jacks, etc., are possibilities. The time needed to apply loads, the safety of the students working with the loading material, measurability and repeatability are important. Therefore, it is recommended that the same people, as provided by the Host Chapter, are used to load the bridges. Make each unit of weight low enough that one individual can lift the weight. Load materials, equipment (and people) should not be damaged if the bridge suddenly fails onto the Safety Support.

5. Spectators should have visual access to the competition. However, it is recommended that spectators should be kept at a safe distance from the construction site.

6. The competition site should be fairly accessible for delivery of materials. It should be relatively level to help leveling abutments, shoring and the Safety Support. Parking lots generally work well. In grassy areas, bolts and small parts can be lost, and abutments can sink into the ground. Permit the layout of materials in the staging yards and the placement of shoring and Safety Support in advance of the timed competition. Use a taut string line between abutments to set the line for placing shoring and the Safety Support.

Markings noting the staging yards, access roads, river, wingwall and other areas can be done with chalk, broad masking tape or anything else available. A wooden strip toeboard, at river's edge, can serve as a definitive line for the river and also help judges detect violations.

7. Camber can best be determined by string line attached to the abutments. A string line attached to the bridge ends with a C-clamp can be used for lateral sideway measurement. For deflections under load testing, use a string line, dial gages, or level observing a marker attached to the bridge or a rod placed periodically on the bridge in the identical location each time.

8. The roadway decking as described for this competition is steel bar grating, generically identified as "W-19-4 (1 x 1/8) steel". Seven pieces 3'-6" in length and 2'-11 3/4" wide are required for a complete bridge. As these pieces of grating are reusable, one set of seven pieces should be sufficient for the competition unless you plan a simultaneous load testing. You may wish to consider getting one extra piece in case one gets damaged. You should be able to secure this grating from a local steel fabricator or supplier.

Alternative roadway decking materials could be timber planking, heavy plywood, or some other suitable product. If alternative decking is used, all competing schools will need plenty of advance notice regarding its size, support requirements, clearance needs and strength.

9. Depending upon the number of entries, you should determine an appropriate schedule for the competition. You may wish to schedule simultaneous construction of two or more bridges, on separate abutments, if you have several entrants. The more bridge-building sites you have available, the faster the competition will go.

Unloading, set-up and layout in the staging yards can be time-consuming for complicated bridges and unpracticed teams. Two separate staging yards are provided at each end of a site. This enables two schools to get set up for the competition at each abutment, saving set-up time.

One way to speed the competition along is to remove each completed bridge, without grating, from the abutments into a temporary storage area. Several students will be needed to lift and carry a bridge, of course. By doing this, all bridges will be built first, then all bridges will be load-tested. You may have to provide short blocks on which to set the bridges during storage.

10. If available, platform scales are preferred. However, bathroom scales will probably be accurate enough to weigh each bridge. In the unloaded condition, without grating, lift up one end of the bridge and place a scale underneath each support point (typically two). Then do this at the other end of the bridge and sum the readings.

11. All bridges that qualify should be recognized, for example, by a "certificate of quality". Awards should be given in each of the categories of competition (stiffest, lightest, fastest construction, aesthetics, most efficient, and most economic), and for overall performance.

**JUDGING FORM (SUGGESTED)**

**Penalties for Accidents**

Builder touches river or safety support (\$50,000 each) \$ \_\_\_\_\_

Bridge part touches river or safety support (\$20,000 each) \$ \_\_\_\_\_

Tool or fastener dropped in river (\$1,000 each) \$ \_\_\_\_\_

TOTAL PENALTIES \$ \_\_\_\_\_

**Construction Time**

\_\_\_\_\_ builders x \_\_\_\_\_ min = \_\_\_\_\_ person-min

**Weight** \_\_\_\_\_ pounds

**Deflection** (incremental vertical, test 3) \_\_\_\_\_ in

**Efficiency**

Total weight (lb) \_\_\_\_\_ /100 = \_\_\_\_\_

Incremental vert. deflect. (in) \_\_\_\_\_ /0.10 = \_\_\_\_\_

SNWD (add) \_\_\_\_\_



**Cost**

Shores: \$80,000 if used \$ \_\_\_\_\_

Const Time \_\_\_\_\_ x \$3,000 = +\$ \_\_\_\_\_

Weight \_\_\_\_\_ x \$1,000 = +\$ \_\_\_\_\_

Total Penalties \$ \_\_\_\_\_

TOTAL COST (add) \$ \_\_\_\_\_

**Aesthetics**

Suggested Items to Consider in Judging Aesthetics:

General Appearance

Blending with the Environment

Quality of Workmanship - Fabrication and Finish

Construction Organization and Teamwork

Balance of Design

Proportions

Cleanliness of Line

Aesthetics Score: \_\_\_\_\_

**Rank**

Construction Speed \_\_\_\_\_ Efficiency \_\_\_\_\_

Lightness \_\_\_\_\_ Economy \_\_\_\_\_

Stiffness \_\_\_\_\_ Aesthetics \_\_\_\_\_

**Overall Performance** (Efficiency + Economy) = \_\_\_\_\_

(may use aesthetics as tie breaker)

0127